

**13573 / 75225****BMW X3****1/9/2008**

GROSS LOAD CAPACITY WHEN USED AS A WEIGHT CARRYING HITCH: 3,500 LBS. TRAILER WEIGHT & 350 LBS. TONGUE WEIGHT.  
 GROSS LOAD CAPACITY WHEN USED AS A WEIGHT DISTRIBUTION HITCH: 4,000 LBS. TRAILER WEIGHT & 400 LBS. TONGUE WEIGHT

**\*\*\*DO NOT EXCEED VEHICLE MANUFACTURER'S RECOMMENDED TOWING CAPACITY.\*\*\***

Parts List			
ITEM	QTY	PART NUMBER	DESCRIPTION
1	4	M12-1.75	HEX FLANGE NUT

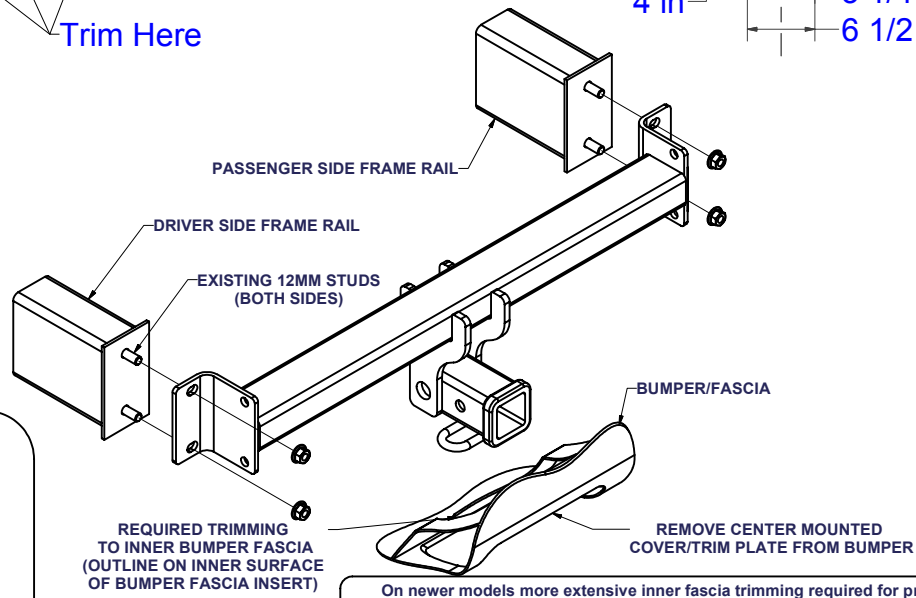
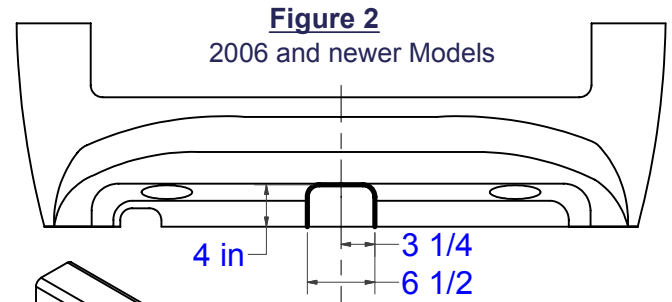
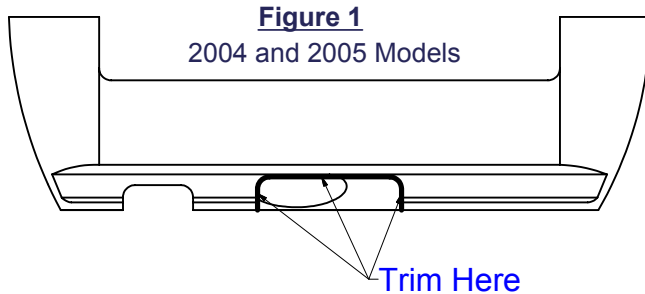

HITCH WEIGHT: 31 LBS.

INSTALL TIME: 3-4 HOURS

**INSTALL NOTES:**

- REMOVE BUMPER FASCIA
- TRIM BUMPER FASCIA
- DISCARD STEEL BUMPER
- REINSTALL BUMPER FASCIA

## INSTALLATION STEPS

- 1) **Remove rear fascia as noted below.**
  - A) On 2004 & 2005 models, remove access door from bottom of fascia and return to vehicle owner.
  - B) Open tail gate, remove corner trim peices, and remove (2) screws, (1) on each side
  - C) Remove (2) screws inside each wheel well. Pull wheel well plastic away from fascia and remove (3) more screws, each side.
  - D) Remove (1) screw and (2) plastic nuts from bottom fascia.
  - E) Carefully pull fascia straight back to remove.
- 2) Trim the fascia.
  - A) 2004 & 2005 Models: trim inner fascia as shown in **Figure 1**. Trim the inner fascia to same profile as the access door. Trimming the outer fascia is not required.
  - B) 2006 Models: trim outer and inner fascia as shown in **Figure 2**. Measure from fascia clearance as shown.
  - C) On newer models more extensive inner fascia trimming is required for proper fit as shown on page 2.
- 3) Remove and discard steel bumper by removing (2) nuts each side, which secure the bumper to the rear vehicle frame.
- 4) Raise hitch into position, in place of steel bumper and secure with M12 flange nuts
- 5) Torque all 12mm fasteners to 60 lb-ft.
- 6) Reinstall fascia.

**PERIODICALLY CHECK THIS RECEIVER HITCH TO ENSURE THAT ALL FASTENERS ARE TIGHT AND THAT ALL STRUCTURAL COMPONENTS ARE SOUND.**

Curt Manufacturing Inc., warrants this product to be free of defects in material and/or workmanship at the time of retail purchase by the original purchaser. If the product is found to be defective, Curt Manufacturing Inc., may repair or replace the product, at their option, when the product is returned, prepaid, with proof of purchase. Alteration to, misuse of, or improper installation of this product voids the warranty. Curt Manufacturing Inc.'s liability is limited to repair or replacement of products found to be defective, and specifically excludes liability for incidental or consequential loss or damage.

13573 / 75225

BMW X3

10/18/2007



MARK OUT THE INNER BUMPER BEAM AS SHOWN TO THE LEFT.



USING A DREMEL OR EQUIVALENT CUTTING TOOL, TRIM BUMPER FASCIA AS SHOWN TO THE RIGHT.

Curt Manufacturing Inc., warrants this product to be free of defects in material and/or workmanship at the time of retail purchase by the original purchaser. If the product is found to be defective, Curt Manufacturing Inc., may repair or replace the product, at their option, when the product is returned, prepaid, with proof of purchase. Alteration to, misuse of, or improper installation of this product voids the warranty. Curt Manufacturing Inc.'s liability is limited to repair or replacement of products found to be defective, and specifically excludes liability for incidental or consequential loss or damage.